



## King County

Department of Transportation

Marine Division

M.S. KSC-TR-0816

201 South Jackson Street

Seattle, WA 98104-3856

August 1, 2017

Engineering and Architectural Services  
Department of Enterprise Services (DES)  
PO Box 41476  
Olympia, WA 98504-1476

Subject: Pier 50 Float Replacement Project  
Application for approval to use the DB Alternative Contracting Method

Dear Members of the Project Review Committee,

The King County Department of Transportation, Marine Division (KCMD) is pleased to submit their application requesting approval to use the Design-Build (DB) alternative contracting method pursuant to RCW 39.10.300 for the passenger-only ferry (POF) float replacement project at Pier 50 in Seattle.

The existing POF float serves the King County Water Taxi routes to West Seattle and Vashon Island from Seattle as well as the new Kitsap Fast Ferry from Bremerton to Seattle. The POF float has reached the end of its useful life and is being replaced to safely transport passengers from the ferry to the pier.

KCMD is building a new passenger-only ferry terminal at Pier 50 as part of a seven-year project at the Washington State Ferries (WSF) Colman Dock Preservation Project. This is a multi-phased project in which KCMD is the first phase. This float project must integrate into the construction schedule for the completion of the new POF terminal to meet in-water permitting timelines that affect the entire Colman Dock Preservation Project.

Since inception in 2008, KCMD has delivered multiple capital projects using both Design-Bid-Build and DB contracting methods. In our experience, the DB contracting method is more cost efficient and effective in meeting project schedules by developing a product that meets the required performance specifications without extensive changes to design during construction. DB allows continuity between design and construction. We have direct experience following the DB procedures in RCW 39.10.300 with the design and construction of our new passenger-only ferries and we propose modeling the Pier 50 Float Replacement project on this successful experience.

Please do not hesitate to contact me with questions or requests for additional information at 206-477-3968 or [ron.panzero@kingcounty.gov](mailto:ron.panzero@kingcounty.gov).

Thank you for your time and consideration of our application.

Sincerely,

Ron Panzero  
Marine Operations and Maintenance Manager

State of Washington  
Capital Projects Advisory Review Board (CPARB)  
**Project Review Committee (PRC)**

**APPLICATION FOR PROJECT APPROVAL**

*To Use the Design-Build (DB) Alternative Contracting Procedure*

The CPARB PRC will only consider complete applications: Incomplete applications may result in delay of action on your application. Responses to Questions 1-8 and 10 should not exceed 20 pages (*font size 11 or larger*). Provide no more than six sketches, diagrams or drawings under Question 9. A Public Body that is **certified** to use the DB procedure and is seeking approval to use this procedure on a DB project with a total project cost of less than **\$10 million** is not required to submit information for Questions 7 or 8.

**1. Identification of Applicant**

- (a) Legal name of Public Body (your organization): [King County Department of Transportation, Marine Division](#)
- (b) Address: [201 South Jackson Street, Seattle, WA 98104](#)
- (c) Contact Person Name: [Ron Panzero](#) Title: [Marine Operations and Maintenance Manager](#)
- (d) Phone Number: [206-477-3968](#) Fax: [None](#)  
E-mail: [ron.panzero@kingcounty.gov](mailto:ron.panzero@kingcounty.gov)

**2. Brief Description of Proposed Project**

[King County Department of Transportation Marine Division \(KCMD\)](#) operates the passenger-only ferry (POF) terminal located at Pier 50 on the Seattle waterfront. KCMD operates two routes from Pier 50, serving Vashon Island and West Seattle. [Kitsap Fast Ferries \(KFF\)](#) are currently operating one new passenger-only ferry route out of Pier 50, and plan to operate two additional routes linking Kitsap County communities with downtown Seattle. The Pier 50 passenger-only ferry operation represents one part of a new multi-model facility for ferries on Puget Sound, located at Colman dock.

The existing float at Pier 50 is at the end of its useful service life with a deteriorating condition. Replacement of this float is necessary to maintain current operations of the King County Water Taxi, accommodate future KFF routes, and lower the increasing facility maintenance costs related to the aging float condition. The project includes construction of a new 117-foot-by-30-foot concrete float, integrated float-mounted passenger loading ramps that will accommodate a variety of vessel freeboard heights, and a 40-foot ramp adjoining an existing 135-foot gangway connection to the new shoreside facility.

The current POF terminal at Pier 50, absent the existing float, is being rebuilt as part of the Colman Dock Preservation Project. King County Department of Transportation (DOT) is a financial partner with Washington State Ferries (WSF), who is the lead agency conducting the preservation project. The Colman Dock Preservation Project is utilizing a General Contractor/Construction Manager (GC/CM) contracting procedure. During the design phase of the Colman Dock Preservation Project, King County DOT received a federal grant to replace the deteriorating float. The desired construction schedule for the replacement float would align with the Colman Dock Preservation Project's new Pier 50 POF facility, thereby completing both projects in the same timeframe and maintaining seamless POF operations for both KCMD and KFF.

**3. Projected Total Cost for the Project:**

**A. Project Budget**

Costs for Professional Services (A/E, Legal, etc.)	\$ 650,000
Estimated project construction costs (including construction contingencies):	\$2,400,000
Equipment and furnishing costs	\$ 240,000
Off-site costs	\$ 0
Contract administration costs (owner, CM, etc.)	\$ 289,000
Contingencies (design & owner)	\$ 890,000
Other related project costs (environmental permitting costs)	\$ 356,000
Sales Tax	\$ 260,000
<b>Total</b>	<b>\$5,085,000</b>

**B. Funding Status**

Please describe the funding status for the whole project.

The Pier 50 Float Replacement Project will be funded through federal and local funding sources. King County DOT received a Federal Transit Administration (FTA) grant for \$3.948 million dedicated to this project. The FTA grant requires a 20% local funding match. In the approved 2017-18 budget, KCMD has secured appropriation to provide the required local match and remaining funds required to complete the project.

**4. Anticipated Project Design and Construction Schedule**

Please provide:

- The anticipated project design and construction schedule, including (1) procurement; (2) hiring consultants if not already hired; and (3) employing staff or hiring consultants to manage the project if not already employed or hired.

The detailed project schedule is included as Attachment A. Key dates from this project schedule are summarized in the following table:

Project Review Committee DB Project Presentation	August 24, 2017
RFQ Advertisement	October 2, 2017
Statements of Qualifications Due	October 27, 2017
Shortlist Finalists	November 3, 2017
Issue RFP to Finalists	November 7, 2017
RFPs Due and Interviews Conducted	January 19, 2018
Finalists Scored and Team Selected	January 24, 2018
Finalize Contract/Notice to Proceed	February 16, 2018
Design and Construction	February 16, 2018 through September 2018

**5. Why the DB Contracting Procedure is Appropriate for this Project**

Please provide a detailed explanation of why use of the contracting procedure is appropriate for the proposed project. Please address the following, as appropriate:

- If the construction activities are highly specialized **and** a DB approach is critical in developing the construction methodology (1) What are these highly specialized activities, and (2) Why is DB critical in the development of them?

Construction of the replacement float is not a typical land-based construction process. Rather, it is a unique marine project requiring specialized design and construction activities, methods, and technologies designed to accommodate waterborne forces such as wind and wave conditions, and vessel interactions. These forces are absorbed and supported by float-mounted pile guides and pilings driven below the seabed. These factors contribute to float stability where passengers can disembark the vessel.

There are only a few companies in the U.S. that build floats of this size, and utilizing the DB process allows KCMD to select the contractor based on qualifications, capabilities, and experience, versus awarding the contract based solely on low price. Additionally, having the design and construction performed by a single team under one contract will reduce the KCMD's risk from diffused responsibility for design and construction. This close, contractual relationship between the design and construction team will result in fewer change orders by KCMD that arise from occasional revisions in DBB. Overall, DB has greater potential to save time and reduce cost because ordering of materials and construction can begin before the total design is completed, thus meeting the timeline of the environmental permits for in-water work.

- If the project provides opportunity for greater innovation and efficiencies between designer and builder, describe these opportunities for innovation and efficiencies.

The DB contracting method will allow the project and construction managers to work directly with the design/construction team concurrently, providing more opportunity for innovative ideas during both design and construction, and reducing potential schedule delays. This close coordination ensures the design will meet KCMD's operational needs and timelines, while increasing project control and construction quality. DB collaboration between the designer and builder should lead to greater time efficiencies and cost savings.

KCMD and the DB team will work together during the design phase to incorporate materials and details into the fabrication process to ensure KCMD's environmental guidelines are met and decrease maintenance over the service life of the float. While this may add to the initial costs, the savings in the life cycle maintenance costs validates this approach.

- If significant savings in project delivery time would be realized, explain how DB can achieve time savings on this project.

KCMD is a small, cost-efficient, marine transit division within the King County DOT. While KCMD has limited management resources to dedicate to construction management of capital projects, it takes advantage of other division resources and experience within King County DOT to assist with capital projects.

The KCMD management team has recent experience in both traditional DBB and DB contracting methods. When comparing these two contracting methods, the DBB approach has required far more resources to achieve a successful outcome, necessitating that staff continuously act as a liaison between the design team and the construction team. By contrast, the DB contracting method has provided one point of contact for both design and construction considerations, resulting in coordination efficiencies for KCMD, project time savings, and effective project delivery.

This project has an aggressive timeline in an effort to meet the Colman Dock Preservation Project environmental work window. The DB approach will allow the KCMD to deliver the float on time through scheduling efficiencies and a shorter, streamlined procurement process already utilized from the DB vessel acquisition project.

## 6. Public Benefit

In addition to the above information, please provide information on how use of the DB contracting procedure will serve the public interest. For example, your description must address, but is not limited to:

- How this contracting method provides a substantial fiscal benefit; or

The DB contracting procedure will serve the public interest by providing a lower project cost through scheduling efficiencies, greater opportunity for value engineering, lowered risk in the design and construction phase, and lower life cycle costs. With the early involvement of a contractor experienced in marine float construction projects, the DB procedure is more likely to produce realistic cost estimates, and reduce change orders and construction delays as the contractor will have direct input into the design and procurement process.

- How the use of the traditional method of awarding contracts in a lump sum (*the “design-bid-build method”*) is not practical for meeting desired quality standards or delivery schedules.

The application of a DB approach for this project will result in only qualified firms providing proposals, ensuring quality standards. Operational efficiencies will be realized by mobilizing construction and suspending ferry operations only once, rather than twice, to complete the entire project. Accordingly, the DB contracting procedure is considered critical to achieving the project efficiencies necessary to meet the aggressive design and construction schedule that aligns with completion of the Colman Dock Project for POF. The DB contracting procedure is anticipated to produce a lower project cost through scheduling efficiencies, greater opportunity for value engineering, lowered project delivery risks, reduced impact on the traveling public, and lower life cycle cost for maintenance.

## 7. Public Body Qualifications

Please provide:

- A description of your organization’s qualifications to use the DB contracting procedure.

KCMD has used both the traditional DBB and DB contracting procedure for capital projects. Using the DB procedure resulted in the successful construction and delivery of two new passenger-only ferry vessels. Before construction, an Expert Review Panel of maritime professionals provided recommendations for the project, including the use of DB process instead of DBB. The RFQ for this project was issued in October 2012, and vessels were delivered in 2015. KCMD project manager Ron Panzero managed this project from start to successful completion.

- A project organizational chart, showing all existing or planned staff and consultant roles.  
**Note:** *The organizational chart must show the level of involvement and main responsibilities anticipated for each position throughout the project (for example, full-time project manager). If acronyms are used, a key should be provided.*

The project organizational chart is included as Attachment B and highlights all existing and planned staff and their roles on this project.

- Staff and consultant short biographies that demonstrate experience with DB contracting and projects (*not complete résumés*).

The following section highlights the key staff who will be working on this project.



**Ron Panzero, KCMD Marine Operations and Maintenance Manager and Pier 50**

**Replacement Float Project Manager:** Ron has over 33 years of experience in the marine industry; 29 of those years with passenger ferries and 17 years of direct experience managing capital improvement projects for ferry systems. While working for Skagit County, Ron managed the capital improvement projects for new ferry propulsion systems and installation, new terminal building, replacement of breakwater, and the replacement of dolphins at the Anacortes and Guemes Island facilities. Since his arrival at KCMD 7 years ago, Ron has managed all aspects of the Division's capital improvement program, overseeing construction and installation of a unique/one-of-a-kind maintenance barge used to facilitate fleet maintenance with a DBB approach; construction of two new state-of-the-art high speed passenger-carrying catamarans (DB), the repowering of an existing vessel in the fleet (DB), and shoreside capital improvement projects at the Vashon Island (DBB) and Seacrest Park (DB). Ron is now set to oversee the design and construction of a new concrete float to replace the existing steel float at Pier 50.

**Paul Brodeur, KCMD Division Director:** Paul Brodeur has over three decades of diverse marine industry experience, and has been the KCMD Division Director for 5 years, where he has been the final approving authority over every capital improvement project undertaken by KCMD. Prior to his employment at KCMD, Paul was the Director of Marine Engineering at WSF, where he directly oversaw the construction of multiple large passenger ferries using the DB approach.

**Henry Perrin, KCMD Project Support:** Henry has 18 years of experience in project management and design. His experience includes work on a variety of environmental and transportation projects with budgets up to \$35 million. He is a Washington State licensed Professional Engineer (PE) and a Project Management Institute (PMI) certified Project Management Professional (PMP). Henry is currently managing the design and construction of the Seattle Ferry Terminal Project, the passenger-only facility at Colman Dock in Seattle.

**Evelyn Wise, KCMD Finance Manager:** Evelyn Wise manages/oversees all financial matters for the KCMD, and has done so since the Division's inception in 2008. She has extensive experience working with capital projects and the application of federal grant funding to the projects, including all aspects of the DB procedures, most recently for the DB design and construction of the two new KCMD passenger ferries.

**Greg Suko, KCDOT Construction Managing Engineer:** Greg Suko has over 30 years of experience in Construction Management (CM) with over 20 years of experience with King County in a variety of senior CM roles, including reasonability for delivering multiple construction projects and sites with a staff of over 20 CM professionals. Greg has successfully delivered on multiple challenging projects such as the Ballard Siphon Replacement (DBB) which included deep shafts exceeding depths of 100 feet, tunneling under Salmon Bay, and slip lining the original wood stave double barrel inverted sewer siphon with HDPE pipe; the Westpoint Treatment Plant's Centrifuge Replacement project (DB) which included maintaining NPDES permit requirements in a continuously operated facility; Westpoint Treatment Plant's 4.6MW Co-generation facility (DBB); and various wastewater pump station upgrades (DBB); to name just a few examples.

- Provide the ***experience and role on previous DB projects delivered*** under RCW 39.10 or equivalent experience for each staff member or consultant in key positions on the proposed project.

Please refer to Attachment C for a list of key staff member's experience and role on previous projects.

- The qualifications of the existing or planned project manager and consultants.  
*Note: For design-build projects, you must have personnel who are independent of the design-build team, knowledgeable in the design-build process, and able to oversee and administer the contract.*

Ron Panzero is the project manager for this project and a list of his project experience can be found in Attachment C.

- If the project manager is interim until your organization has employed staff or hired a consultant as the project manager indicate whether sufficient funds are available for this purpose and how long it is anticipated the interim project manager will serve.

Not applicable. Ron Panzero will be the permanent project manager for the duration of the project and will be supported by construction management staff from King County DOT Transit Division.

- A brief summary of the construction experience of your organization's project management team that is relevant to the project.

Since 2008, KCMD has established a capital improvement program to increase the vessel fleet configuration, provide infrastructure and maintenance facilities to support the new vessels, and improve passenger amenities to meet the increasing ridership demand. The contracting methods for each project have included traditional DBB, DB, and GC/CM. The DB project list and experience can be found in Attachment D. The following list includes a brief summary of these capital projects:

- **Seacrest Park Float and Pier (DBB):**
  - Project Description: construction and installation of new float, pier, and gangway.
  - Total Cost: approximately \$1.2M.
  - **Project Manager: Don Campbell** managed construction activities and change orders and conducted project close out.
  - **Support Staff: King County Transit** provided project control and documentation, and inspection services.
- **Maintenance Barge (DBB):**
  - Project Description: construction and installation on waterfront of barge with maintenance facility.
  - Total Cost: approximately \$6M.
  - **Project Manager: Ron Panzero** managed construction activities, inspections, and change orders, and conducted project close out.
  - **Support Staff: Julia Turney** construction management, **King County Roads Division**, project control and documentation.
- **New Passenger Vessels Construction (DB):**
  - Project Description: construction of two new catamaran passenger ferries.
  - Total cost: approximately \$13M.
  - **Project Manager: Ron Panzero** assisted in developing the contract terms, selected the DB team, managed construction activities and change orders, and conducted project close out.
  - **Support Staff: Dave Watson**, construction management, **HMS Consulting**, Contract management and inspection services, **King County Roads Division**, project control and documentation

- **Vashon Terminal Improvements (DBB):**
  - Project Description: construction of a cover, windscreen and handrail on a passenger walkway.
  - Total Cost: approximately \$0.3M.
  - **Project Manager: Ron Panzero** managed construction activities and change orders, and conducted project close out.
  - **Support Staff: Dave Watson**, construction management, **King County Roads Division**, project control and inspection services, **King County Transit** providing documentation
  
- **Seacrest Gangway Construction & Pile Guide and Fender Replacement (DB):**
  - Project Description: construction and installation of new ADA ramp, new pile guides, and new fendering to support new vessels.
  - Total Cost: approximately \$0.3M.
  - **Project Manager: Ron Panzero** managed construction activities, contract management, change orders, and inspections, and conducted project close out.
  - **Support Staff: Dave Watson**, construction management, **King County Roads Division**, project control and documentation
  
- **Colman Dock Passenger-only Ferry Terminal (GC/CM):**
  - Project Description: construction of a new passenger-only ferry terminal as part of the Colman Dock Preservation Project.
  - Total Cost: approximately \$29M.
  - **Project Manager: Henry Perrin** construction management activities and change orders with the GC/CM.
  - **Support Staff: King County Roads** providing documentation control **King County Transit** providing project control.
  
- A description of the controls your organization will have in place to ensure that the project is adequately managed.

King County has established extensive standards and procedures, outlined in the Transit Division 2015 Project Management Manual. This project will follow these specified procedures as well as the contract terms outlined in the RFQ.

Ron Panzero is the dedicated project manager, with experience directly applicable to managing a project of this nature. KMCD will rely on the assistance of other King County departments and construction management resources for comprehensive support for this project, including the KC Transportation and Transit Divisions. This approach has been very successful in past projects and will be supporting this project (see Attachment B).

KCMD has developed processes and protocols for effectively managing projects that includes the following:

- Management and Strategic Decision Making:
  - KCMD is supported by a management team that works closely together to assess risk and determine the best approach for the division.
  - Decisions are tracked and communicated in writing and included in the project file.
- Communications:
  - When forming the project team, KCMD prepares a communication plan so the project team knows who to contact at each stage in the project.
  - Key team members are included on each email correspondence to be informed on all communications related to the project.



- Monitoring Progress:
  - As part of the KCMD reporting requirements, the DB team will be required to provide weekly progress updates.
- Controlling Schedule and Budget:
  - A project schedule will be maintained on a weekly basis in coordination with the DB team.
  - KCMD requires monthly invoicing.
- A brief description of your planned DB procurement process.

The DB procurement process will be conducted in the following stages:

1. Request for Qualifications
2. Request for Proposals
3. Request for Best and Final Offer (if necessary).

Following evaluation of the Statement of Qualifications, KCMD will select, at its sole discretion, the highest scored Respondents to become “Proposers.” Selection of Proposers will be based on Statements of Qualifications only; interviews will not be conducted.

KCMD will accept Proposals only from DB teams selected as Proposers. Following evaluation of the Proposals, KCMD will select, at its sole discretion, the highest scored Proposer (considering qualifications, technical and commercial factors, and price). The selection of the Top-Ranked Proposer (TRP) will be based on the scores received by each Proposer and their written Proposal.

During the submittal phase, KCMD may additionally conduct separately-scored interviews with Proposers to assist in selecting the TRP. It is the intent of KCMD to enter into negotiations with the TRP to execute a contract. If KCMD is unable to execute a contract with the TRP, negotiations with the TRP may be suspended or terminated and KCMD may proceed to negotiate with the next highest scored team. KCMD shall continue in accordance with this procedure until a contract agreement is reached or the selection process is terminated. Ultimately, the County reserves the right to request Best and Final Offers (BAFO) from all Proposers.

Verification that your organization has already developed *(or provide your plan to develop)* specific DB contract terms.

KCMD will rely upon and be held accountable to the policies and procedures established by King County. King County has a well-established procurement office/staff. As the project manager, Ron Panzero will work with the KC procurement office, using their collective and direct experience with DB contract terms to develop appropriate terms for this contract. These contract terms and conditions will be reviewed by King County Prosecuting Attorney’s Office (PAO) and contract specialists within the King County organization in support of this KCMD procurement process.

**8. Public Body (your organization) Construction History:**

Provide a matrix summary of your organization’s construction activity for the past six years outlining project data in content and format per the attached sample provided: *(See Example Construction History. The applicant shall use the abbreviations as identified in the example in the attachment.*

- Project Number, Name, and Description
- Contracting method used
- Planned start and finish dates
- Actual start and finish dates

- Planned and actual budget amounts
- Reasons for budget or schedule overruns

Please refer to Attachment D for a list of construction projects completed for KCMD.

**9. Preliminary Concepts, sketches or plans depicting the project**

To assist the PRC with understanding your proposed project, please provide a combination of up to six concepts, drawings, sketches, diagrams, or plan/section documents which best depict your project. In electronic submissions these documents must be provided in a PDF or JPEG format for easy distribution. (See Example concepts, sketches or plans depicting the project.) At a minimum, please try to include the following:

- A overview site plan (indicating existing structure and new structures)
- Plan or section views which show existing vs. renovation plans particularly for areas that will remain occupied during construction.

*Note: Applicant may utilize photos to further depict project issues during their presentation to the PRC.*

The site plan and section views are included as Attachment E.

**10. Resolution of Audit Findings on Previous Public Works Projects**

If your organization had audit findings on *any* project identified in your response to Question 8, please specify the project, briefly state those findings, and describe how your organization resolved them.

There have been no negative audit findings in KCMD's construction history.

**CAUTION TO APPLICANTS**

The definition of the project is at the applicant's discretion. The entire project, including all components, must meet the criteria to be approved.

**SIGNATURE OF AUTHORIZED REPRESENTATIVE**

In submitting this application, you, as the authorized representative of your organization, understand that: (1) the PRC may request additional information about your organization, its construction history, and the proposed project; and (2) your organization is required to submit the information requested by the PRC. You agree to submit this information in a timely manner and understand that failure to do so shall render your application incomplete.

Should the PRC approve your request to use the DB contracting procedure, you also understand that: (1) your organization is required to participate in brief, state-sponsored surveys at the beginning and the end of your approved project; and (2) the data collected in these surveys will be used in a study by the state to evaluate the effectiveness of the DB process. You also agree that your organization will complete these surveys within the time required by CPARB

I have carefully reviewed the information provided and attest that this is a complete, correct and true application.

Signature:   
 Name (please print): Ron Panzero  
 Title: Marine Operations and Maintenance Manager  
 Date: August 1, 2017

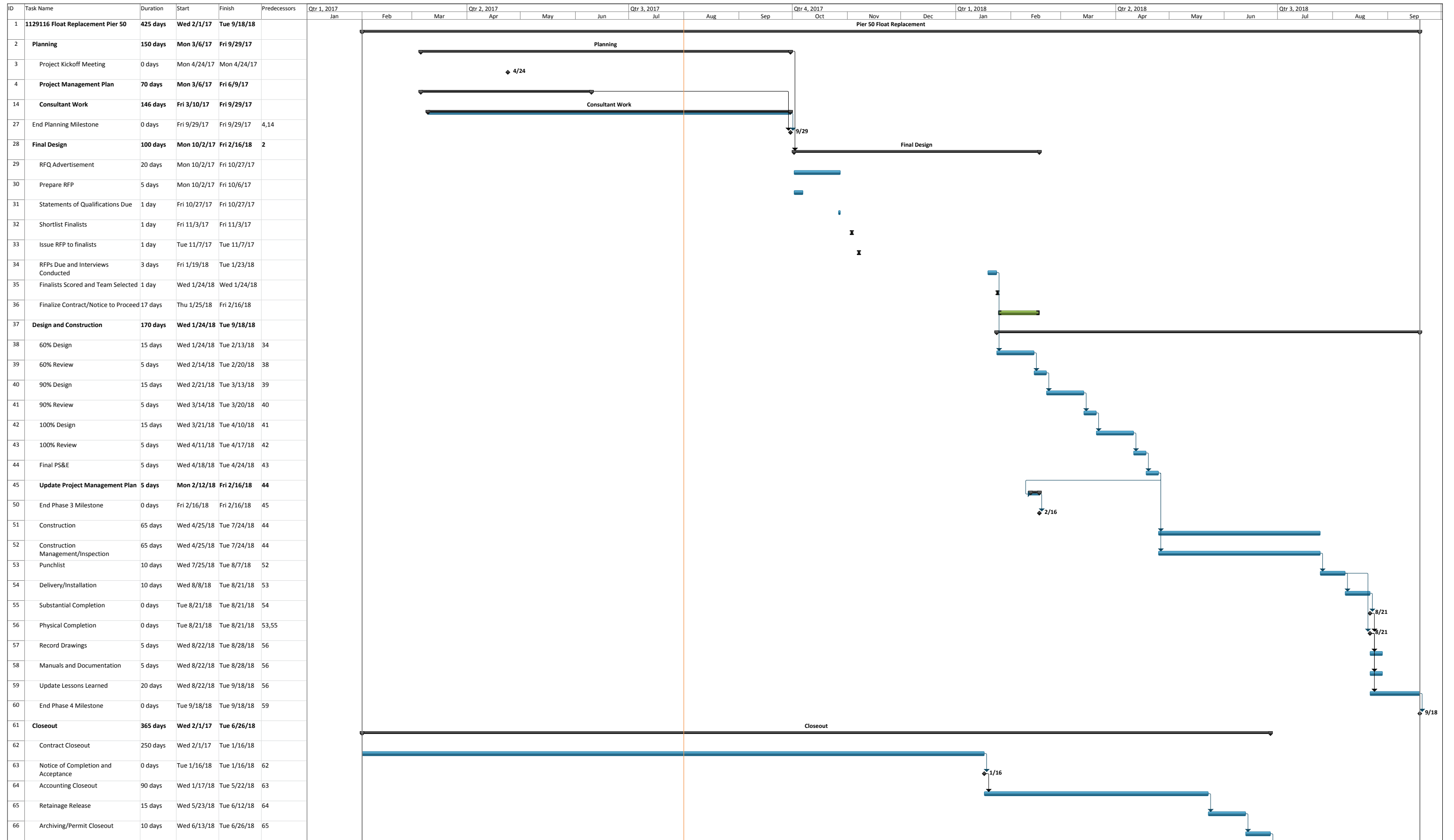

**Project Organization Chart**  
Pier 50 Float Replacement

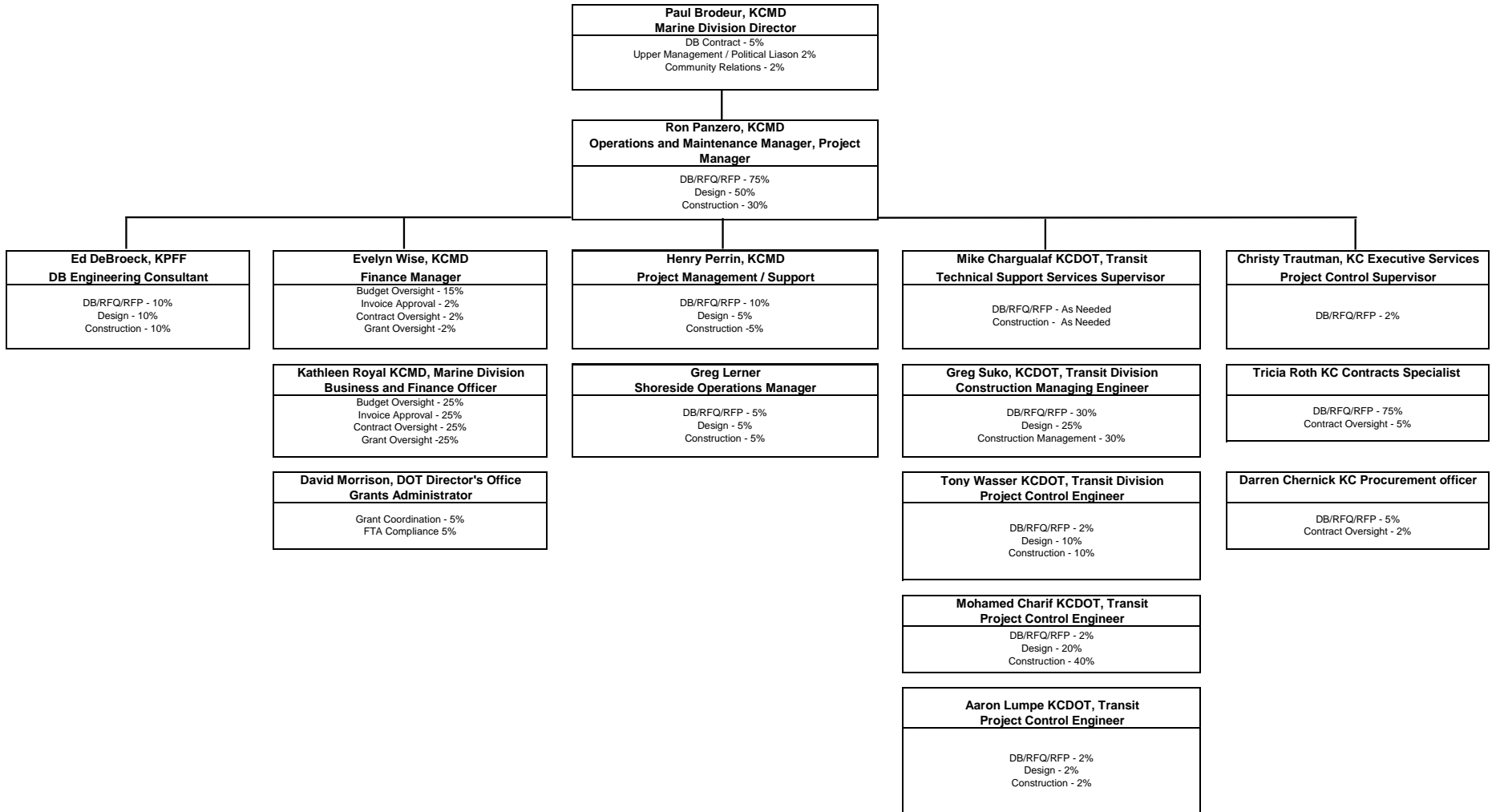

## Project Experience

Name	Summary of Experience	Project Names	Project Size	Project Type	Role during Project Phases		
					Planning	Design	Construction
Ron Panzero	PM	Maintenance Barge New Passenger Vessel Construction Vashon Terminal Improvements Seacrest Float Repair and Modifications	\$5.9M \$13.2M \$544K \$365K	DBB DB DBB DBB	PM	PM	PM
Paul Brodeur	Director	Maintenance Barge New Passenger Vessel Construction Vashon Terminal Improvements Seacrest Float Repair and Modifications Colman Dock Preservation Project, Pier 50 POF	\$5.9M \$13.2M \$544K \$365K \$28M	DBB DB DBB DBB GC/CM	Division Director	Division Director	Division Director
Henry Perrin	Construction Manager	Colman Dock Preservation Project, Pier 50 POF	\$28M	GC/CM	NA	Construction Manager	Construction Manager
Ed Debroeck	Structural Design Engineer	Pontoon Construction Facility SR 520 Floating Bridge and Landings WETA Alameda Passenger Boat Maintenance Facility and Emergency Operations Center NAVY Indian Island Float Replacement	\$360M \$766M \$50M \$4M	DB DB DB DB	Structural Design Engineer	Structural Design Engineer	Structural Design Engineer
Tony Wasser	Project Controls	KCIA Main Terminal Renovation KCIA Sound Insulation Program (aka Residential Aircraft Noise Remedy Improvements Program, or RANRIP) ARFF Apparatus Taxiway Alpha Rehabilitation & Related Work New ARFF Facility Construction	\$7.5M \$38M \$1.1M \$26.3M \$7.2M	DBB DBB G&S DBB DBB	Project Controls	Project Controls	Project Controls
Greg Suko	Construction Manager	Westpoint Treatment Plant Centrifuge Replacement Ballard Siphon Replacement Interbay Pump Station Upgrade South Magnolia Combined Sewer Overflow Storage Westpoint Treatment Plant Influent Screening Improvements Westpoint Treatment Plant Office Annex Construction Westpoint Treatment Plant 4.6 MW Co-Generation Facility	\$11M \$34.6M \$12.6M \$15.5M \$10.8M \$1.5M \$10M	DB DBB DBB DBB DBB DBB DBB	CM	CM	CM
Trisha Roth	Contracts Specialist	Operating and Maintenance Facility East (Sound Transit) Tacoma Trestle (Sound Transit) Lynnwood Link Extension (L200)	\$219M \$60M \$400M	DB DBB GCCM	Contracts Specialist Asst	Contracts Specialist	Contracts Specialist

## King County DOT, Marine Division - Construction History (6 years)

Project #	Project Name	Project Description	Contracting Method	Planned Start	Planned Finish	Actual Start	Actual Finish	Planned Budget	Actual Budget	Reason for Budget or Schedule Overrun
1	Seacrest Float Replacement	Replacement of all existing floats, shoreside ramp, and ramp to support passenger ferry service.	D-B-B	Oct-08	Apr-10	Oct-08	Apr-10	\$1M	\$1M	
2	Maintenance Barge	Temporary (3-5 years) installation of a 140'x40'x7'6" barge with moorage for four vessels, and a maintenance workshop and two-story office and crew quarters.	D-B-B	May-10	Aug-12	May-10	Jun-13	\$5.9M	\$5.9M	Shipyard Delays
3	New Passenger Vessels Construction	Construction of two new passenger-only vessels for KCMD.	D-B	Jan-13	Dec-15	Jan-15	Dec-15	\$13.66M	\$13.57M	Owner Change Orders
4	Vashon Terminal Improvements	Terminal improvements to increase passenger comfort, including a windscreen and cover on the gangway.	D-B-B	Mar-13	Feb-15	Feb-16	Dec-16	552K	\$544K	Two Rounds of Bids
5	Seacrest Float Repair and Modifications	Replacement of pile guides, fendering, and new ramp to support passenger ferry service.	D-B-B	Jun-15	Nov-15	Nov-15	Mar-16	\$350K	\$365K	Unanticipated Repair Work
6	Colman Dock Preservation Project, Pier 50 Passenger-only Facility	New terminal facility at Pier 50 that includes increased queuing capacity, an employee office and storage area. This project also includes construction of a public walkway to connect the multi-modal facility to the adjacent transit facilities.	GC/CM	Aug-17	Sep-18	Aug-17	Ongoing	\$28 million	Ongoing	



Legend

- Programmed POF Facilities (Colman Dock Project)
- POF Float Replacement
- New WSF Trestle and Loading (Colman Dock Project)
- Replaced WSF Terminal Facilities (Colman Dock Project)

Note: Features not drawn to scale.



POF Float Replacement

Note: This figure is for reference only and the float size and configuration are subject to change as design advances.



# KING COUNTY WATER TAXI PIER 50 FLOAT REPLACEMENT DRAFT SUBMITTAL 07.14.2017

DRAWING INDEX		
SHEET NO.	DRAWING NO.	TITLE
<b>GENERAL</b>		
1	T1.1	TITLE SHEET
2	G1.1	GENERAL NOTES & ABBREVIATIONS
3	G2.1	SITE PLAN
4	G2.2	FLOAT PLAN
5	G3.1	SITE SECTION
<b>STRUCTURAL</b>		
6	S1.1	STRUCTURAL NOTES SHEET 1
7	S1.2	
8	S2.1	SITE PLAN
9	S2.2	SITE SECTION
10	S2.3	FLOAT SURFACE FEATURES PLAN
11	S2.4	FLOAT ELEVATION
12	S3.1	GANGWAY ATTACHMENT PLAN
13	S3.2	GANGWAY SUPPORT FRAME
14	S4.1	RAISED DECK PLAN AND SECTIONS
15	S4.2	RAISED DECK DETAILS
16	S5.1	WEST GUIDE PILE HOOP
17	S5.2	WEST GUIDE PILE SECTIONS
18	S5.3	EAST GUIDE PILE HOOP
19	S6.1	FENDER ELEVATION AND DETAILS
20	S7.1	HANDRAIL PLAN AND SECTIONS
21	S8.1	FLOAT STRUCTURAL NOTES
22	S8.2	FLOAT CONCRETE PLAN AND SECTION
23	S8.3	FLOAT CONCRETE DETAILS
24	S8.4	FLOAT CONCRETE DETAILS
<b>CIVIL / UTILITIES</b>		
25	C1.1	CIVIL / UTILITIES NOTES
26	C1.2	UTILITIES SURFACE PLAN
27	C1.3	
28	C2.1	
29	C2.2	
<b>MECHANICAL</b>		
30	M1.1	
31	M1.2	
32	M2.1	
33	M2.2	
34	M2.3	
<b>ELECTRICAL</b>		
35	E1.1	ELECTRICAL NOTES
36	E1.2	
37	E2.1	
38	E2.2	
39	E2.3	

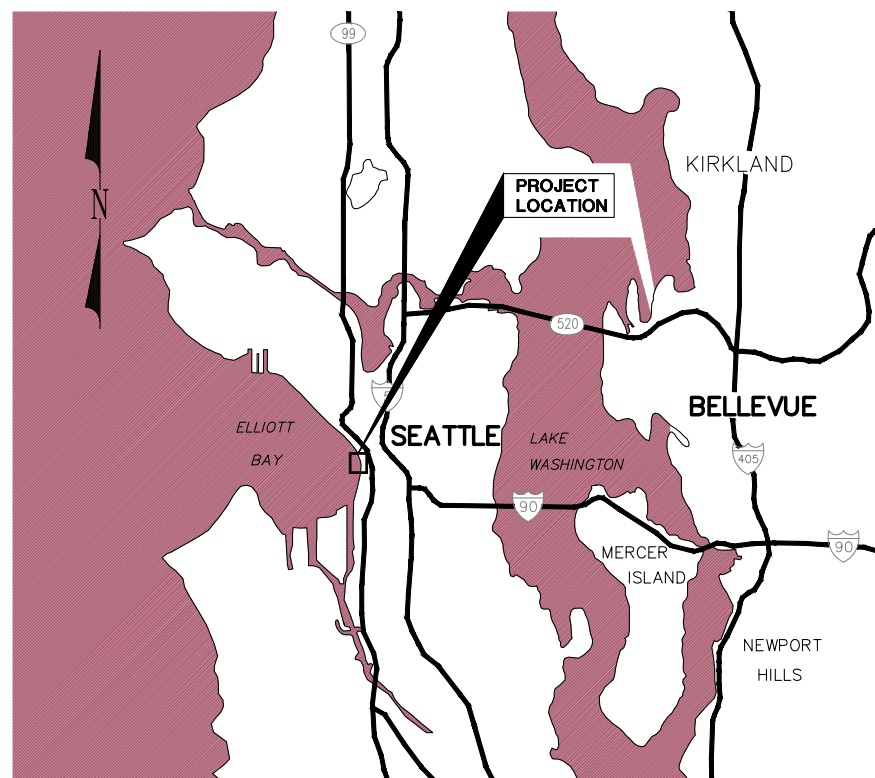

VICINITY MAP



LOCATION MAP

DRAFT SUBMITTAL 7/14/2017

SURVEY JOB NO: _____	--	--					
CHECKED: _____	--	--					
CAD ENTERED: _____	--	--					
DESIGNED: _____	--	--					
CHECKED: _____	--	--					
SUPERVISOR: _____	--	--					
	NUM.	REVISION	BY	DATE			

FED. AID No. _____	--
PROJECT No. _____	--
MAINTENANCE DIVISION No. _____	--

**kpff**

1601 5th Avenue, Suite 1300  
Seattle, Washington 98101  
(206) 382-0600 Fax (206) 382-0500

KING COUNTY DEPT. OF TRANSPORTATION  
HAROLD TANIGUCHI, DIRECTOR  
**MARINE DIVISION**  
**KING COUNTY WATER TAXI**  
PIER 50 – SEATTLE, WASHINGTON  
KING COUNTY PASSENGER ONLY FERRY TERMINAL  
TITLE SHEET & INDEX

SHEET  
**1 (K)**  
OF  
**XX**  
SHEETS

XXX-XX T1.1

DRAFT SUBMITTAL 7/14/2017

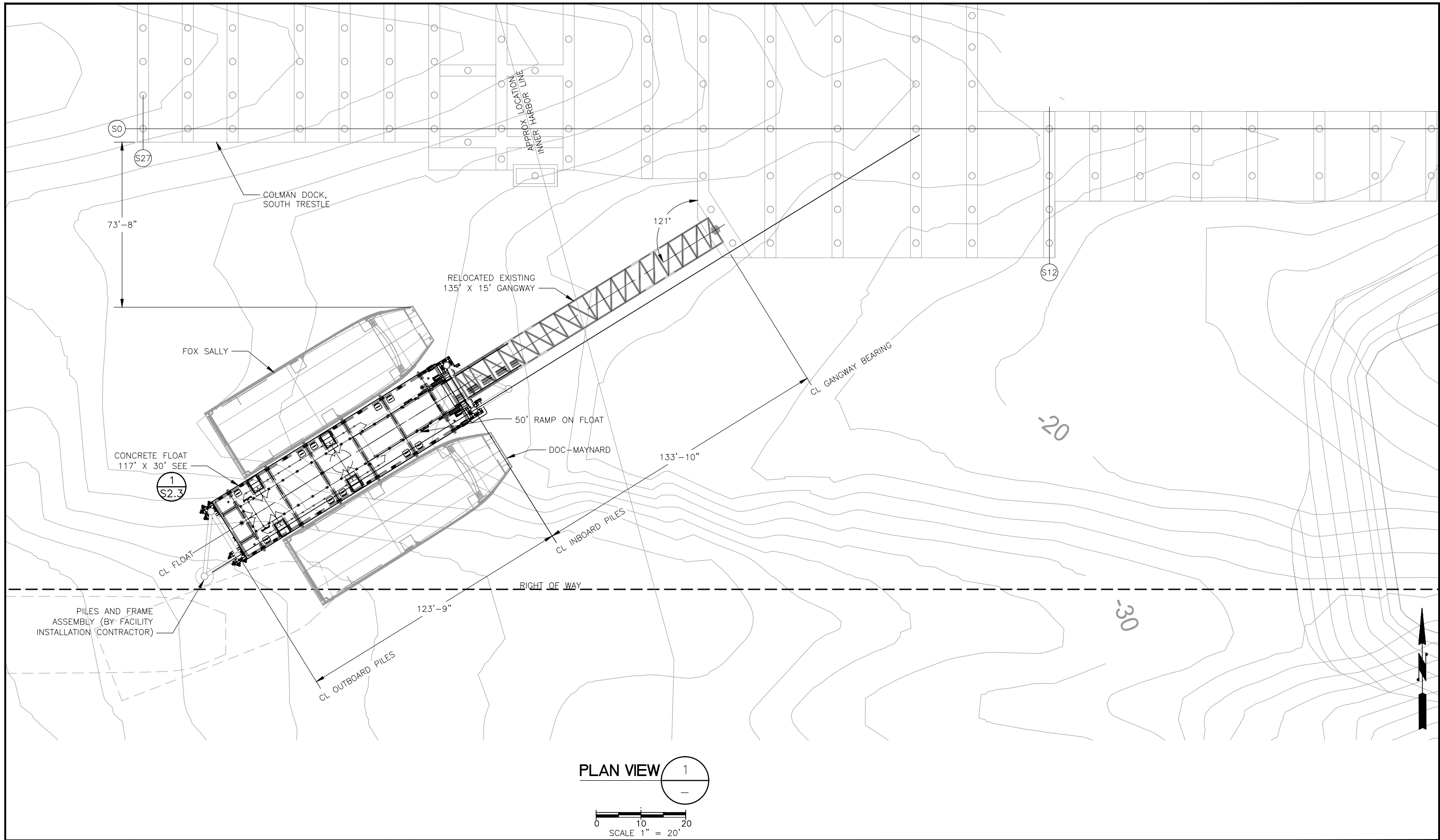

PLAN VIEW 1

0 10 20  
SCALE 1" = 20'

SURVEY JOB NO: ---	---				
CHECKED: ---	---				
CAD ENTERED: ---	---				
DESIGNED: ---	---				
CHECKED: ---	---				
SUPERVISOR: ---	---				
		NUM.	REVISION	BY	DATE

FED. AID No. ---

PROJECT No. ---

MAINTENANCE DIVISION No. ---



KING COUNTY DEPT. OF TRANSPORTATION  
HAROLD TANIGUCHI, DIRECTOR  
**MARINE DIVISION**  
**KING COUNTY WATER TAXI**  
PIER 50 - SEATTLE, WASHINGTON  
KING COUNTY PASSENGER ONLY FERRY TERMINAL  
SITE PLAN

SHEET 1 (K) OF XX SHEETS

**XXX-XX S2.1**

DRAFT SUBMITTAL 7/14/2017

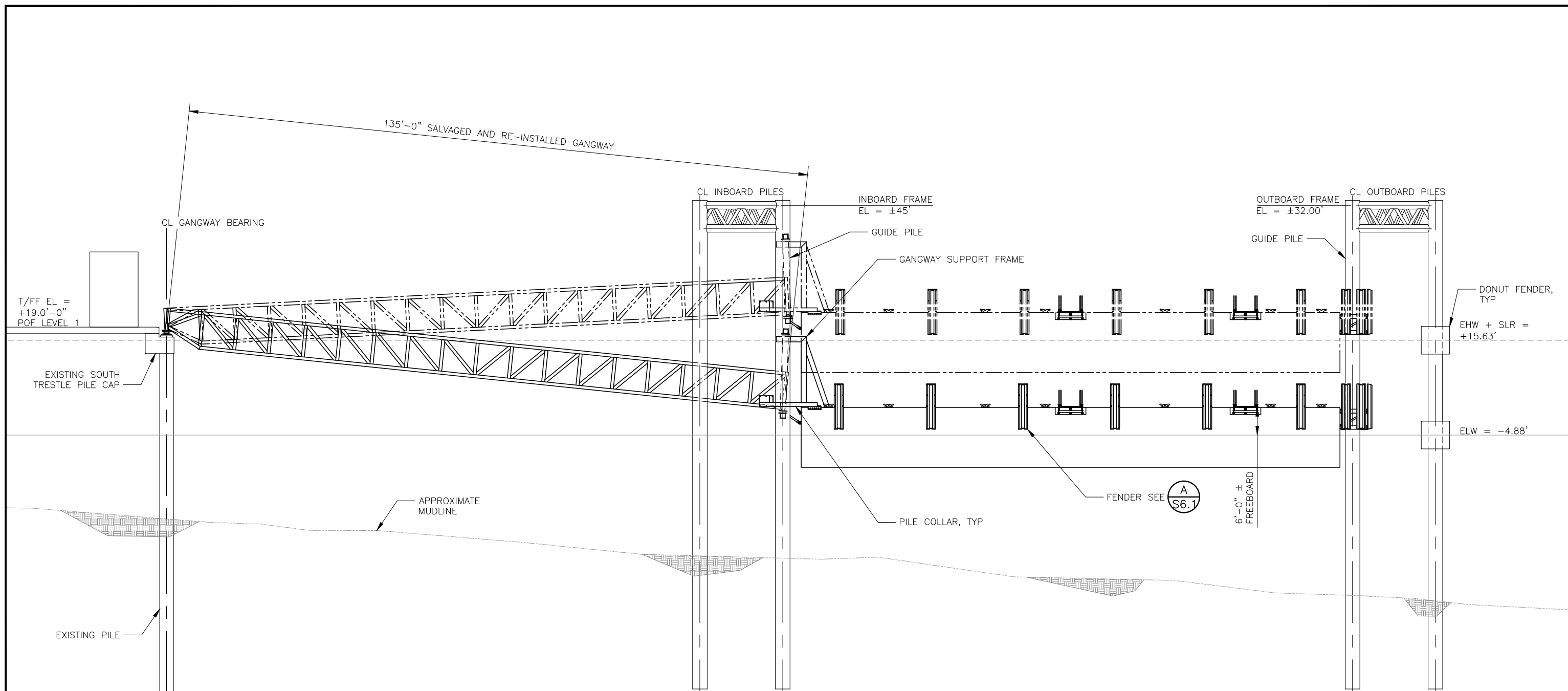

- NOTES:
1. GANGWAY WALK SURFACE SLOPE AT EHW IS APPROX 6.7%
  2. GANGWAY WALKING SLOPE AT ELW IS APPROX 10.8%
  3. GANGWAY WALK SURFACE SURFACE AT WL IS 10' IS APROX 0%

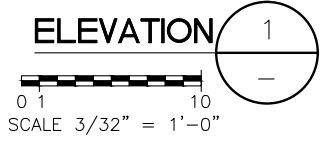

SURVEY JOB NO: ---	---			
CHECKED: ---	---			
CAD ENTERED: ---	---			
DESIGNED: ---	---			
CHECKED: ---	---			
SUPERVISOR: ---	---			
		NUM.	REVISION	BY DATE

FED. AID No. ---

PROJECT No. ---

MAINTENANCE DIVISION No. ---



KING COUNTY DEPT. OF TRANSPORTATION  
 HAROLD TANIGUCHI, DIRECTOR  
**MARINE DIVISION**  
**KING COUNTY WATER TAXI**  
 PIER 50 - SEATTLE, WASHINGTON  
 KING COUNTY PASSENGER ONLY FERRY TERMINAL  
 SITE SECTION

SHEET 1 (K) OF XX SHEETS

**XXX-XX S2.2**

DRAFT SUBMITTAL 7/14/2017

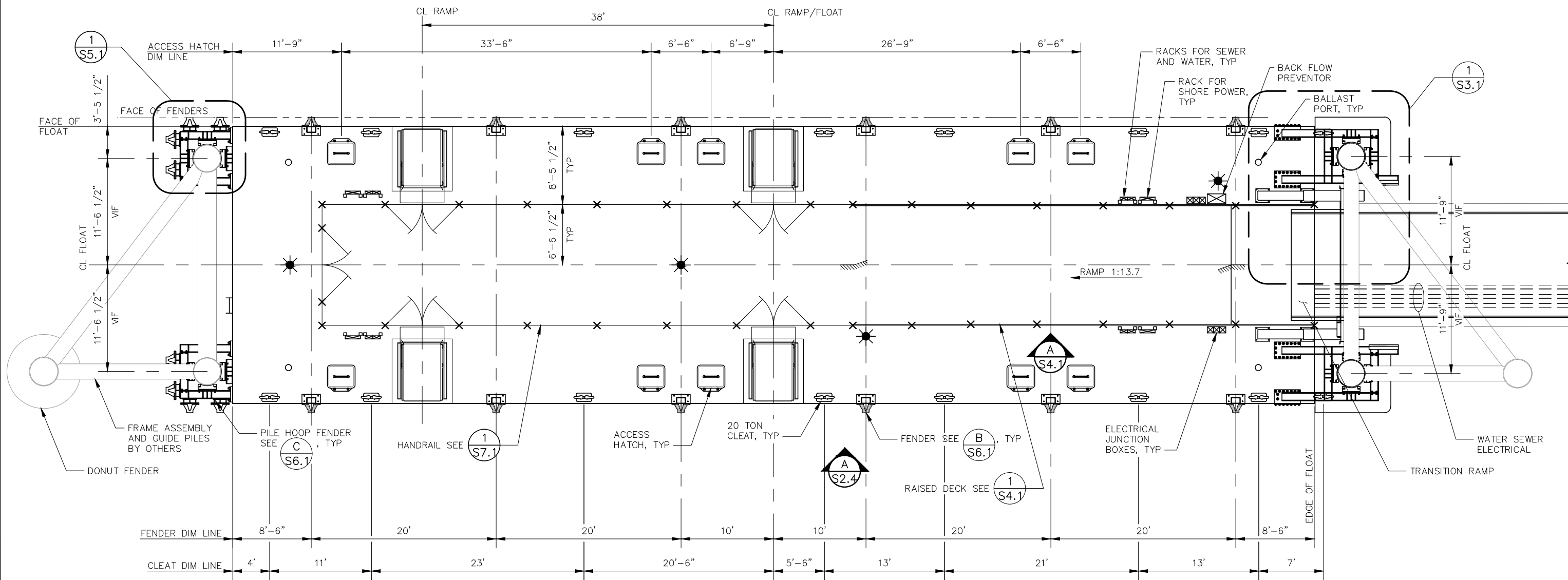

- LEGEND**
- LIGHT POLE
  - BACK HOW PREVENTOR
  - ELECTRICAL JUNCTION BOXES
  - RACK FOR SHORE POWER
  - RACK FOR LINE STORAGE
  - RAILING
  - LADDER
  - CLEAT

**PLAN VIEW** 1  
S2.1

SCALE 3/16" = 1'-0"

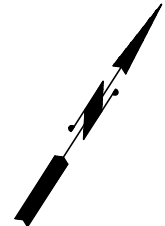

SURVEY JOB NO: _____	--	--					
CHECKED: _____	--	--					
CAD ENTERED: _____	--	--					
DESIGNED: _____	--	--					
CHECKED: _____	--	--					
SUPERVISOR: _____	--	--					
	NUM.	REVISION	BY	DATE			

FED. AID No. \_\_\_\_\_

PROJECT No. \_\_\_\_\_

MAINTENANCE DIVISION No. \_\_\_\_\_



KING COUNTY DEPT. OF TRANSPORTATION  
 HAROLD TANIGUCHI, DIRECTOR  
**MARINE DIVISION**  
**KING COUNTY WATER TAXI**  
 PIER 50 - SEATTLE, WASHINGTON  
 KING COUNTY PASSENGER ONLY FERRY TERMINAL  
 FLOAT SURFACE FEATURES PLAN

SHEET **1 (K)**  
OF  
**XX**  
SHEETS

**XXX-XX S2.3**

DRAFT SUBMITTAL 7/14/2017

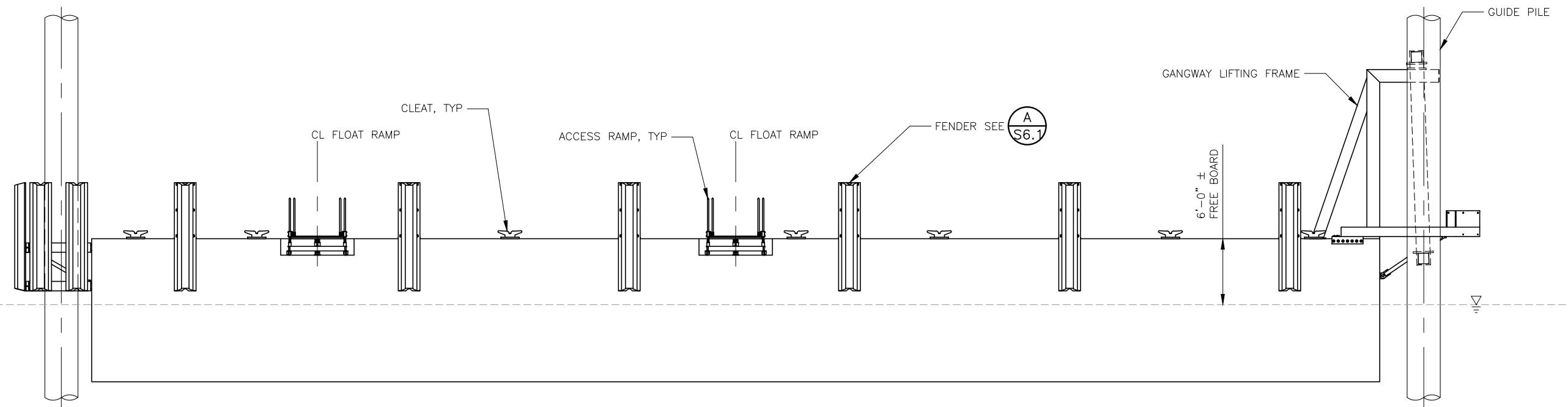

FLOAT ELEVATION (A) S2.3

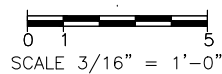

SURVEY JOB NO: ---	---			
CHECKED: ---	---			
CAD ENTERED: ---	---			
DESIGNED: ---	---			
CHECKED: ---	---			
SUPERVISOR: ---	---			
		NUM.	REVISION	BY DATE

FED. AID No. ---  
 PROJECT No. ---  
 MAINTENANCE DIVISION No. ---



KING COUNTY DEPT. OF TRANSPORTATION  
 HAROLD TANIGUCHI, DIRECTOR  
**MARINE DIVISION**  
**KING COUNTY WATER TAXI**  
 PIER 50 – SEATTLE, WASHINGTON  
 KING COUNTY PASSENGER ONLY FERRY TERMINAL  
 FLOAT ELEVATION

**King County**

SHEET 1 (K) OF XX SHEETS  
**XXX-XX S2.4**



DRAFT SUBMITTAL 7/14/2017

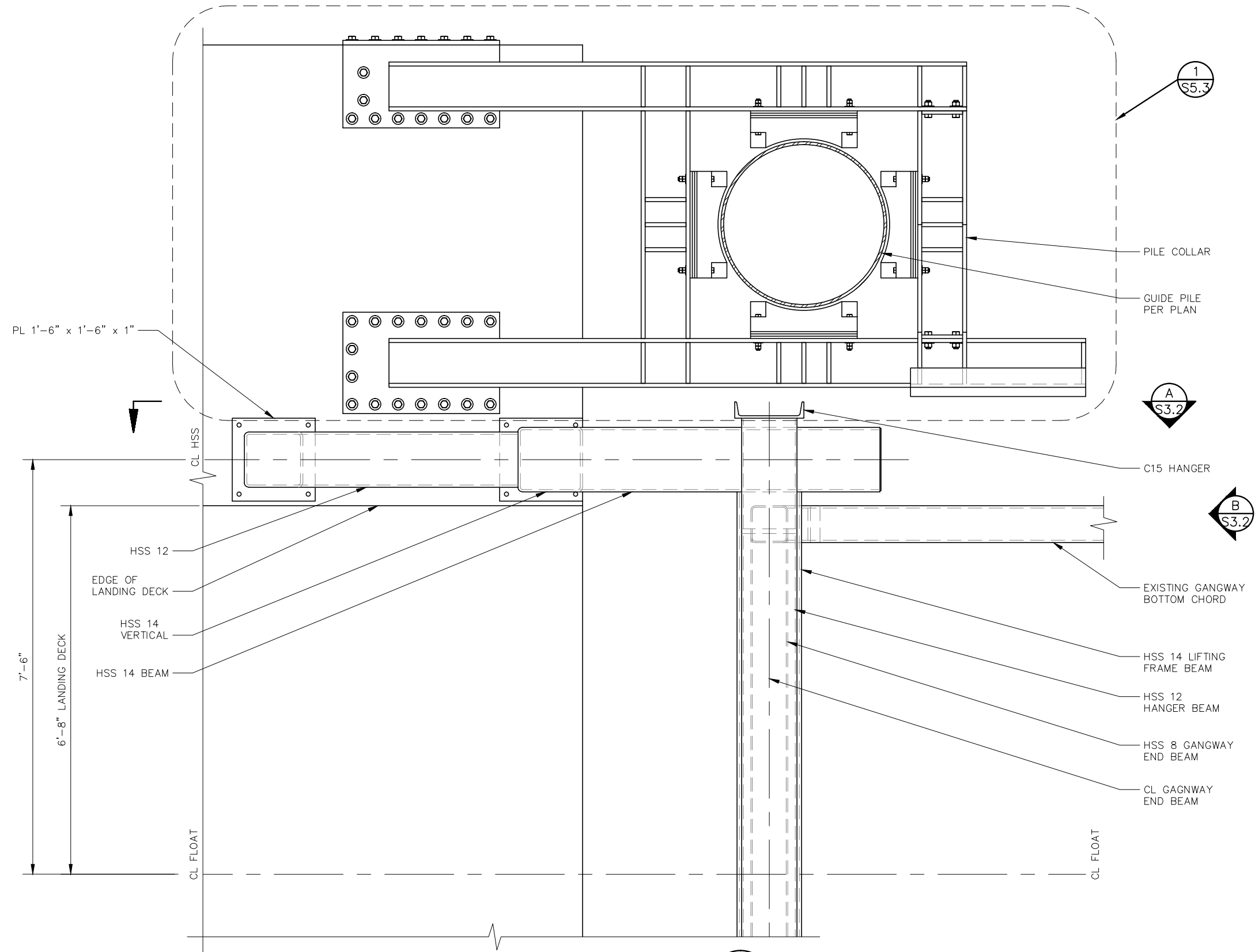

**PLAN VIEW** 1  
 0 6 12  
 SCALE 1" = 1'-0"

SURVEY JOB NO: _____	---	---			
CHECKED: _____	---	---			
CAD ENTERED: _____	---	---			
DESIGNED: _____	---	---			
CHECKED: _____	---	---			
SUPERVISOR: _____	---	---			
	NUM.	REVISION	BY	DATE	

FED. AID No. _____
PROJECT No. _____
MAINTENANCE DIVISION No. _____



1601 5th Avenue, Suite 1300  
Seattle, Washington 98101  
(206) 382-0600 Fax (206) 382-0500

KING COUNTY DEPT. OF TRANSPORTATION  
 HAROLD TANIGUCHI, DIRECTOR  
**MARINE DIVISION**  
**KING COUNTY WATER TAXI**  
 PIER 50 - SEATTLE, WASHINGTON  
 KING COUNTY PASSENGER ONLY FERRY TERMINAL  
 GANGWAY ATTACHMENT PLAN



SHEET  
**1 (K)**  
 OF  
**XX**  
 SHEETS

**XXX-XX S3.1**

DRAFT SUBMITTAL 7/14/2017

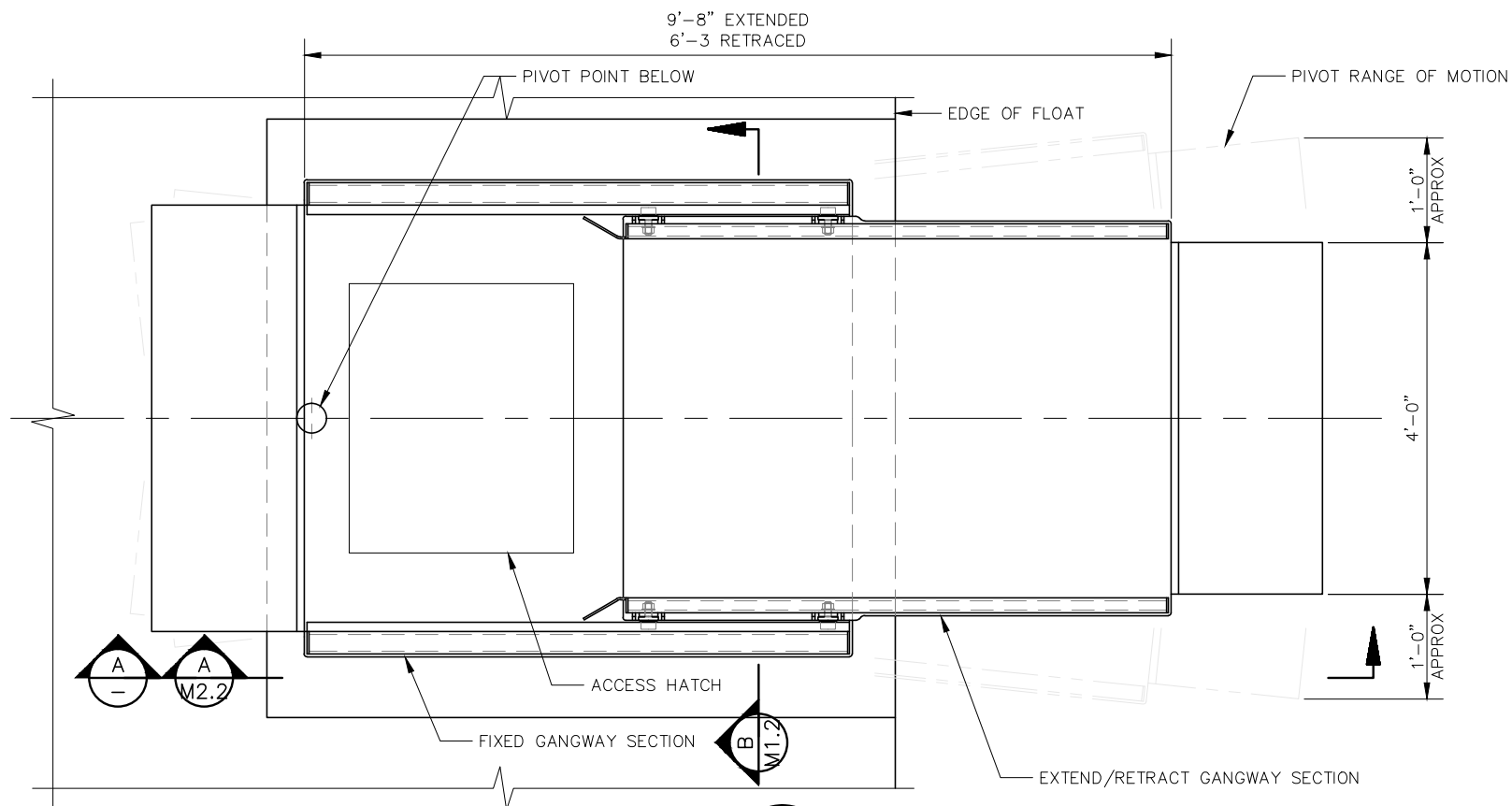

**PLAN AT GANGWAY** 1  
 GANGWAY EXTENDED S2.3  
 SCALE 1" = 1'-0"

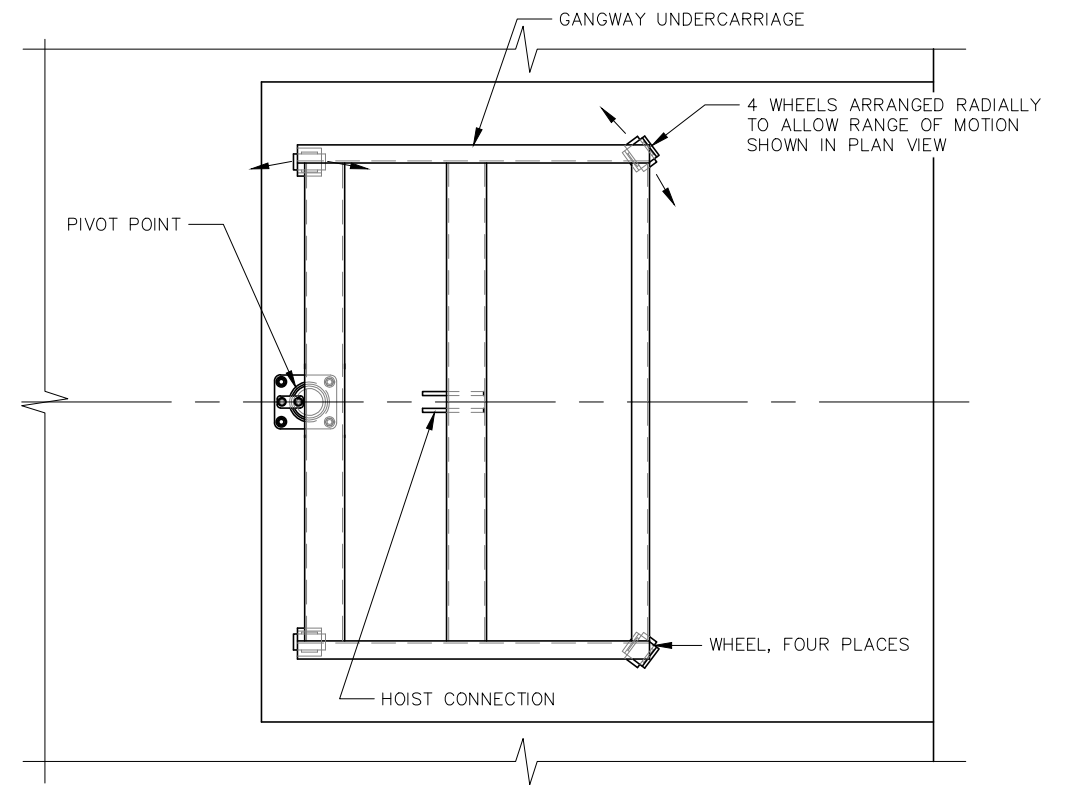

**PLAN AT GANGWAY UNDERCARRIAGE** 2  
 GANGWAY REMOVED  
 SCALE 1" = 1'-0"

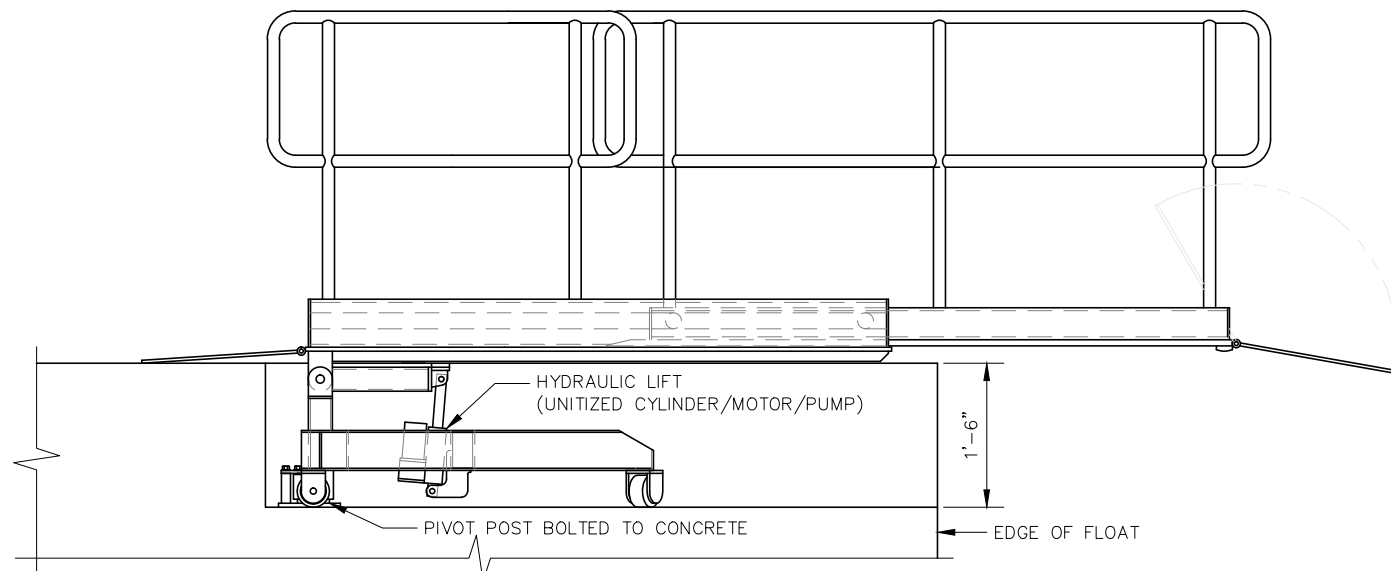

**SECTION** A  
 GANGWAY EXTENDED  
 SCALE 1" = 1'-0"

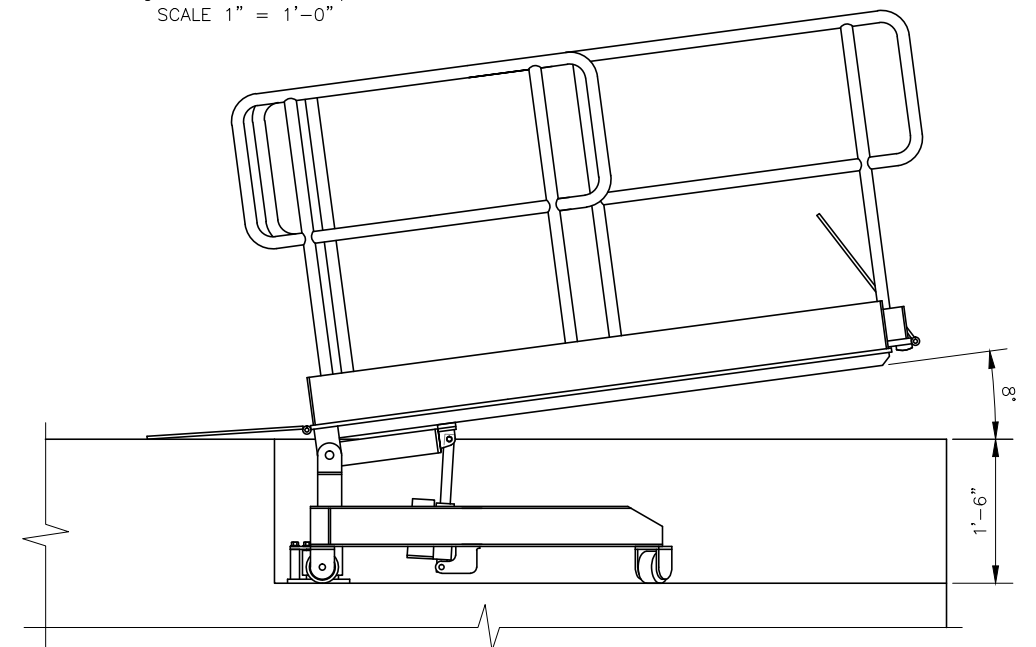

**SECTION** A  
 GANGWAY STOWED  
 SCALE 1" = 1'-0"

SURVEY JOB NO:	---	---
CHECKED:	---	---
CAD ENTERED:	---	---
DESIGNED:	---	---
CHECKED:	---	---
SUPERVISOR:	---	---

NUM.	REVISION	BY	DATE

FED. AID No. \_\_\_\_\_  
 PROJECT No. \_\_\_\_\_  
 MAINTENANCE DIVISION No. \_\_\_\_\_



KING COUNTY DEPT. OF TRANSPORTATION  
 HAROLD TANIGUCHI, DIRECTOR  
**MARINE DIVISION**  
**KING COUNTY WATER TAXI**  
 PIER 50 - SEATTLE, WASHINGTON  
 KING COUNTY PASSENGER ONLY FERRY TERMINAL  
 PASSENGER GANGWAY ARRANGEMENT

SHEET **1 (K)** OF **XX** SHEETS  
**XXX-XX M1.1**